

Dear Jack, Dear Louise: The Intermingling of Artistry and Technology

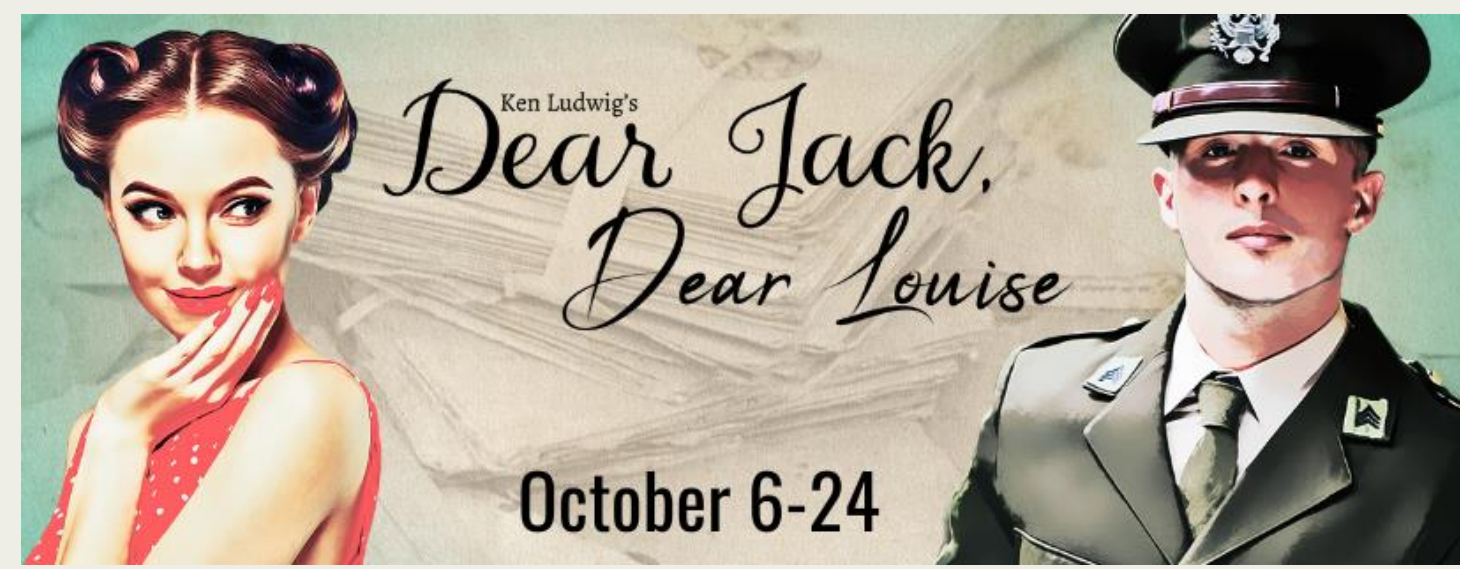

Jordan House, Undergraduate Researcher
Department of Theatre- College of Art & Letters

Assistant Scene Design- A.D. Players at the George Theater:
The Intermingling of Artistry and Technology

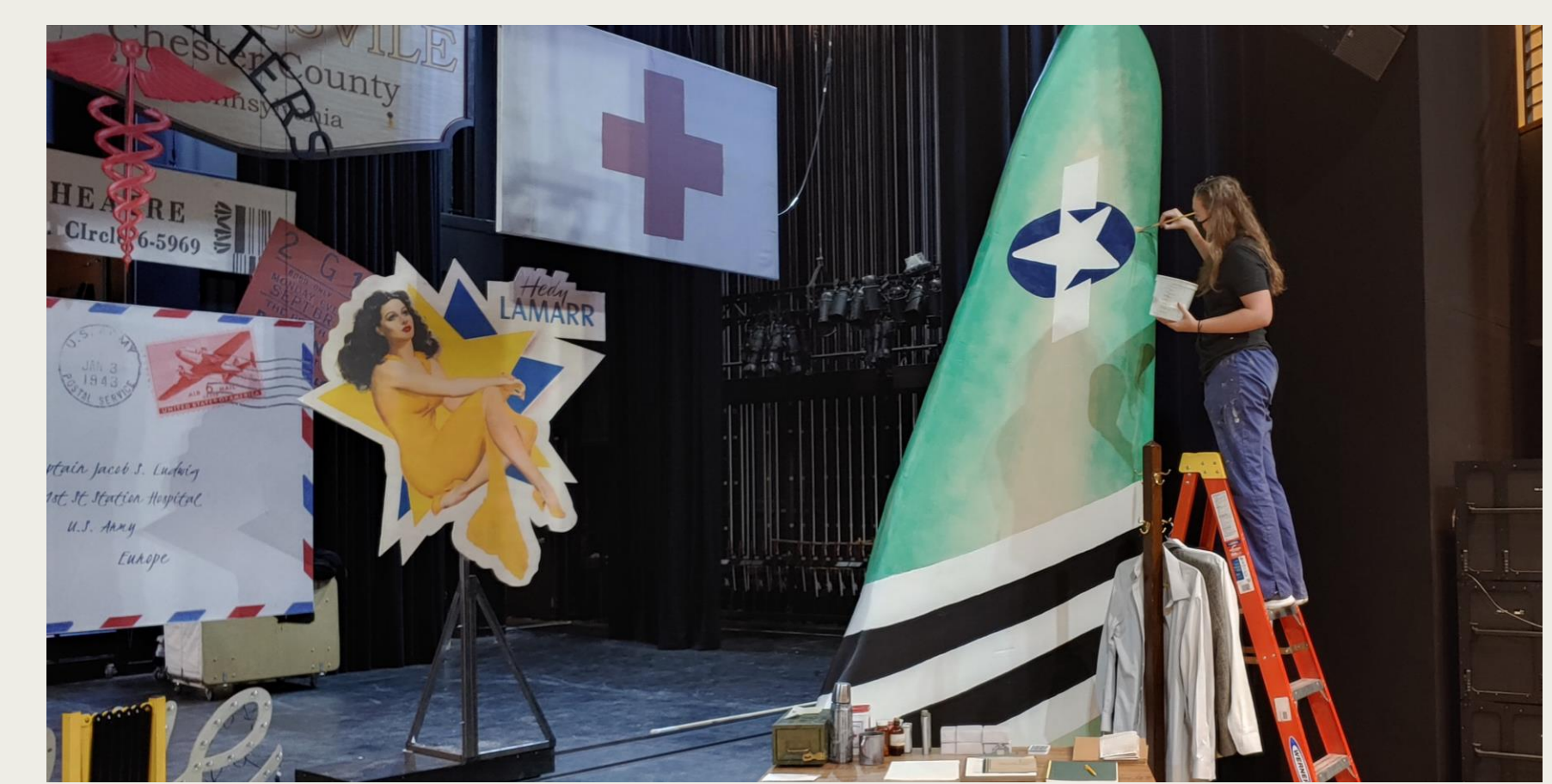

Process photos of the paint treatment by Jordan House

Production Team

- Directed by Kevin Dean
- Costume Des. by Kristina Miller
- Lighting Des. by Jack Jacobs
- Property Des. by Charly Topper
- Scene Des. by Kirk A. Domer
- Sound Des. by Shawn St. John
- Technical Dir. by Michael Mullins
- Asst. Scene Des. by Jordan House



Production photo of *Dear Jack, Dear Louise* at the George Theater in Houston, TX

Project Experience

- ❖ Learned painting techniques to create faux tile and metal textures and multiple wood grains
- ❖ Explored color theory to match, highlight, shadow, and touch up printed designs
- ❖ Developed techniques of blending and feathering to create highlights and shadows
- ❖ Experimented with different materials to make long lasting and reusable stencils to create a repeated pattern
- ❖ Created computer aided drafts that were later translated into full scale furniture used in the production
- ❖ Gained valuable professional experience and created quality pieces to add to a design portfolio

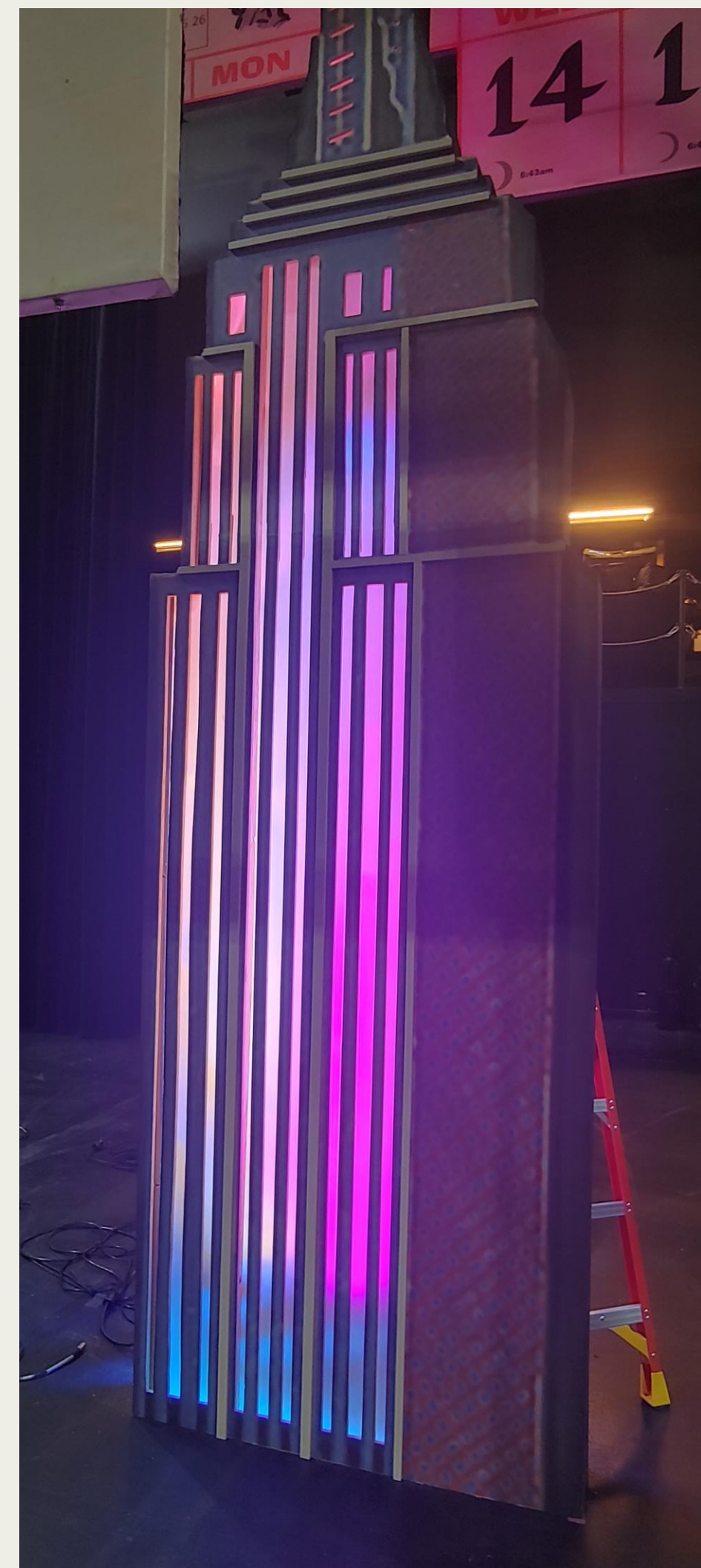

Example of printed scenery with touched up edges and added highlights and shadows

Project Background

- ❖ *Dear Jack, Dear Louise* produced by the A.D. Players at The George Theater in Houston, Texas
- ❖ The play tells the story of how Louise Rabiner and Jack Ludwig (the playwright's parents) met and fell in love by letter during World War II
- ❖ Served as assistant scene designer to Professor Kirk Domer in a professional regional theater
- ❖ Worked with the Scene Designer, Properties Artisan, Technical Director and carpentry team onsite in Houston, Texas

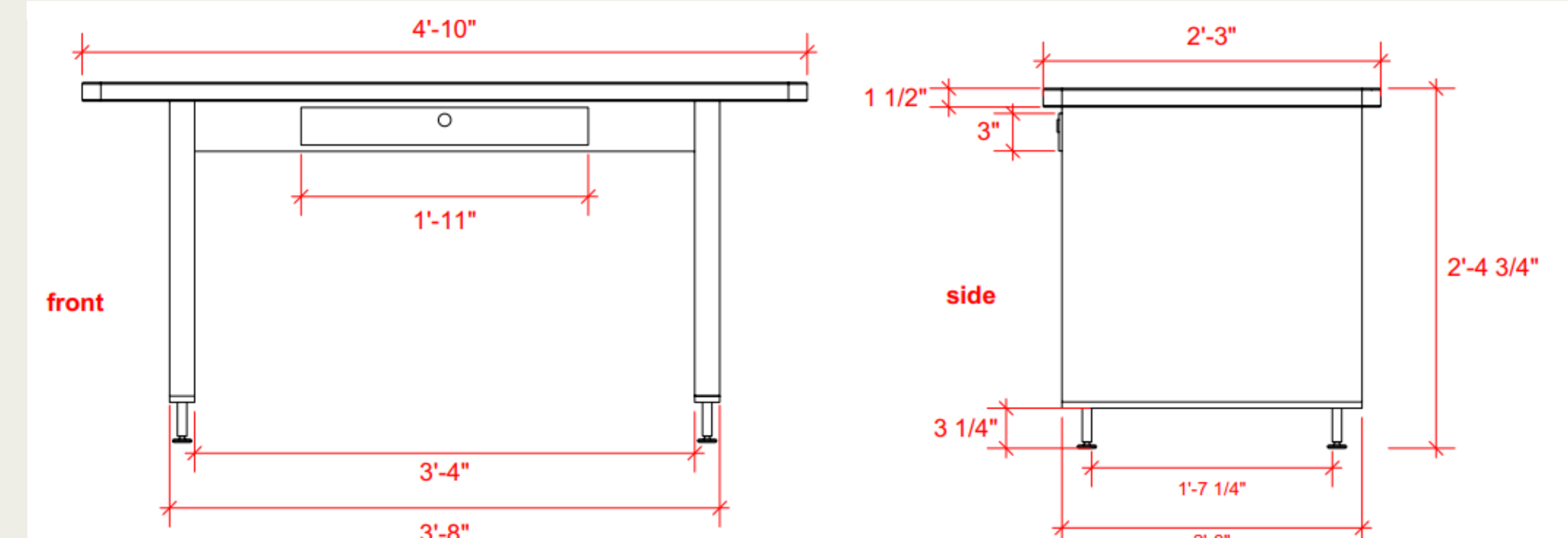

<p>Dear Jack, Dear Louise</p> <p>Jack's Desk</p> <p>Kirk Domer Jordan House</p> <p>George Theater</p> <p>SHI-1</p>			
<p>Notes:</p> <ul style="list-style-type: none"> - scale change in isometric views 1" = 1/2" - round detail on false drawer front is a lock - potential foot option 1 for sale on ebay (\$32 for four feet) - potential foot option 2 from home depot (\$24 for four) 			



Inspiration for the stage floor design



2 of 120 tiles painted by Jordan House that made up half of the stage floor design

Project Abstract

For *Dear Jack, Dear Louise*, a play by Ken Ludwig, I served as the assistant scene designer to Professor of Scene Design Kirk Domer at Michigan State University's Department of Theatre. The research revolved primarily **around learning and implementing painting techniques to create a variety of faux textures, including tile, multiple wood grains, and metal. Using Rosco Off-Broadway Scenic paints, color theory was employed to match, highlight, shadow, and touch up printed designs on the flown scenery.** Professional-quality paint samples and drafting were completed before the residency, becoming valuable additions to a student design portfolio.

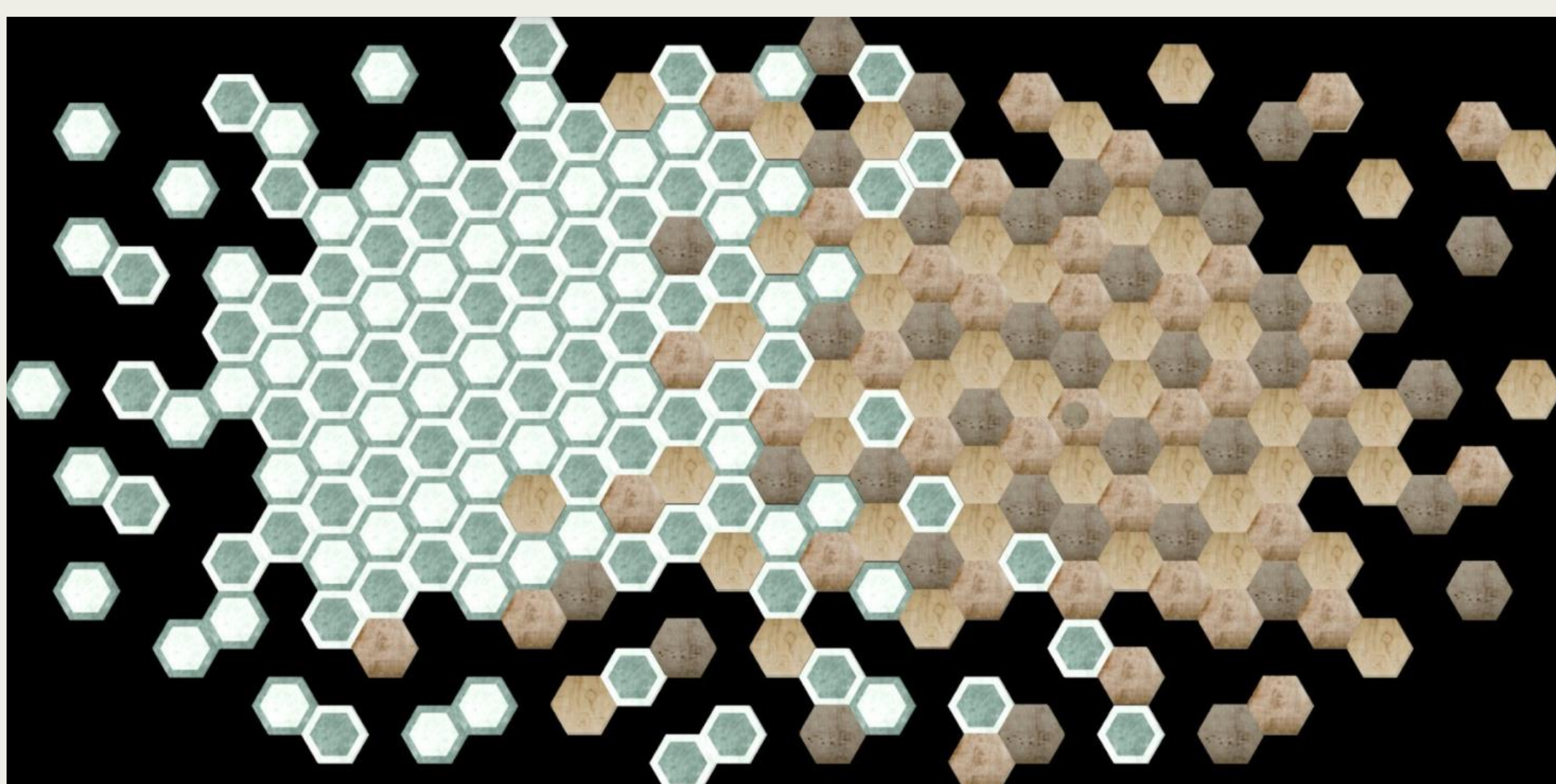

Floor rendering by Kirk A. Domer for the scene design of *Dear Jack, Dear Louise*